

3 PC STAINLESS STEEL BALL VALVE

FULL PORT, 1000 WOG, PN64

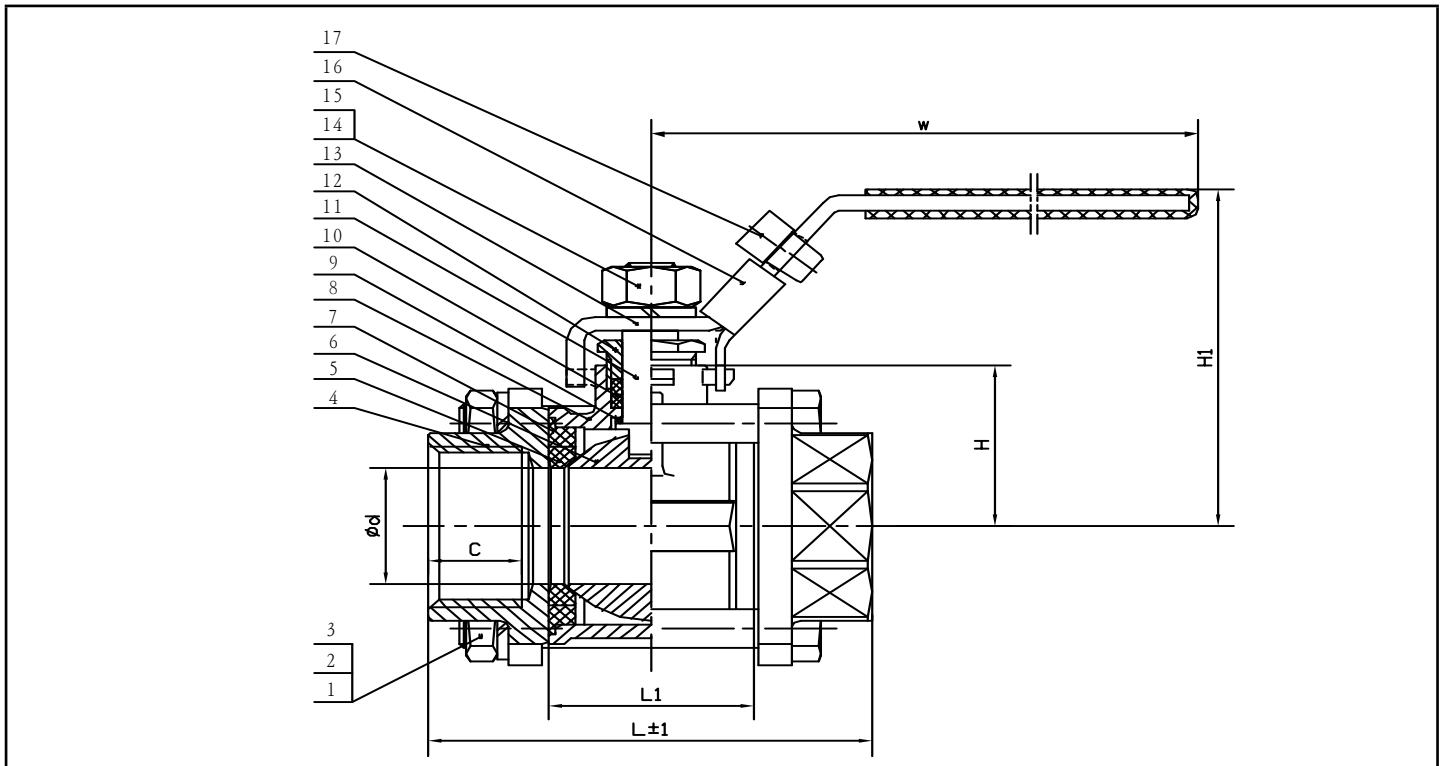

SIZE	Ød	L	H	H1	W	C	L1	MAIN TECHNICAL PARAMETER			
								NORMAL PRESSURE		1000	Psi
3/8"	12	60	25	58	98	12	22	Test pressure	Shell test pressure	10.5	MPa
1/2"	14	60	26	59	98	13.5	25		Tightness test	7.7	
3/4"	20	70	30.5	67	120	14	32		Gas-Tightness Test	0.6	
1"	24	80	33.5	70	120	17	37	Max working temperature		-20 ~ 180	°C
1-1/4"	31.5	92	41	80.5	150	18	45	Applicable medium: water, gas, oil, acid			
1-1/2"	38	107	50	94	170	20	54	TECHNICAL SPECIFICATION 1 Basic design and manufacture according to ANSI B16.34 2 BSPT Threaded ends 3 Inspection and tested according to API598			
2"	48	125	58	102	170	22	66				
2-1/2"	64	160	72.5	125	250	29	84				
3"	76	180	83	135.5	250	29.5	100				
4"	98	225	105	165.5	300	33	128				

NO	PARTS NAME	MATERIAL	NO	PARTS NAME	MATERIAL
1	BOLT	A193-B8	10	PACKING	PTFE
2	SPRING WASHER	A193-B8	11	STEM	A276 316
3	NUT	A194-8	12	PACKING GLAND	A276 304
4	END CAP	A351 CF8M	13	HANDLE	A276 201
5	SEAT	PTFE/RPTFE	14	SPRING WASHER	A193-B8
6	BALL	SS316	15	HANDLE NUT	A194-8
7	GASKET	PTFE	16	HANDLE LOCK	A276 201
8	BODY	A351 CF8M	17	PIN	PLASTIC
9	STEM GASKET	PTFE			